

# INSTALLATION INSTRUCTIONS

## 85mm EVO SPEEDOMETER w/WARNING & PEAK

### WHITE/AMBER /BLUE / GREEN LED DISPLAY

---

#### ❑ BEFORE YOU START

1. Read instructions completely before installation.
2. Install speedometer only when engine is cool and ignition is off.
3. Make sure all necessary tools, materials, and parts are on hand.
4. Refer to your vehicle's service manual for the location of speedometer sensor port, vacuum system, and/or charging system.
5. Disconnect negative (-) battery cable before installing speedometer.

NOTE: It may be necessary to reprogram your radio, clock, etc. after reconnecting the battery.

6. Make sure mounting location does not impair visibility of interfere with driving. Also check behind the mounting location for any wiring or components before drilling.
7. When connecting electrical wire, install crimp terminals and make wire splices as needed. ALWAYS insulate wire splices with electrical tape to prevent shorting.
8. Follow all necessary safety procedures for protection.

#### ❑ SPEED RANGE SWITCH SELECTION

1. Use the switches <1.2.3.4.5.6.7.8.9.0> to adjust the **SPEED** into an approximate range.
2. Switch toward <0.9.8.7.6.5.4.3.2.1.> to narrow the range.  
Switch toward <1.2.3.4.5.6.7.8.9.0.> to widen the range.

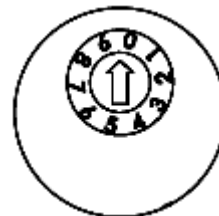

#### ❑ MOUNTING

You can mount your speedometer on or under the dashboard or on the center console according to your personal choice. Determine best position for good visibility before drilling screw holes.

#### ❑ SPEEDOMETER CONNECTION

1. Connect power wire (RED) to +12V battery wire.
2. Connect power wire (WHITE) to a switched +12V circuit at fuse box, or splice into any vehicle harness wire which is energized ONLY when ignition key is ON (RUN) position.
3. Connect power wire (BLACK) to ground, negative (-) battery terminal or a good chassis ground.
4. Connect power wire (ORANGE) to panel lights circuit at fuse box, or splice into any vehicle harness wire connected to the panel lights circuit.
5. Secure lead wires along their route to prevent damage from sharp edges, moving parts or hot engine components.
6. Turn on ignition. DO NOT START ENGINE speedometer Lcd display should be to minimum or "0" when ignition is turned on.

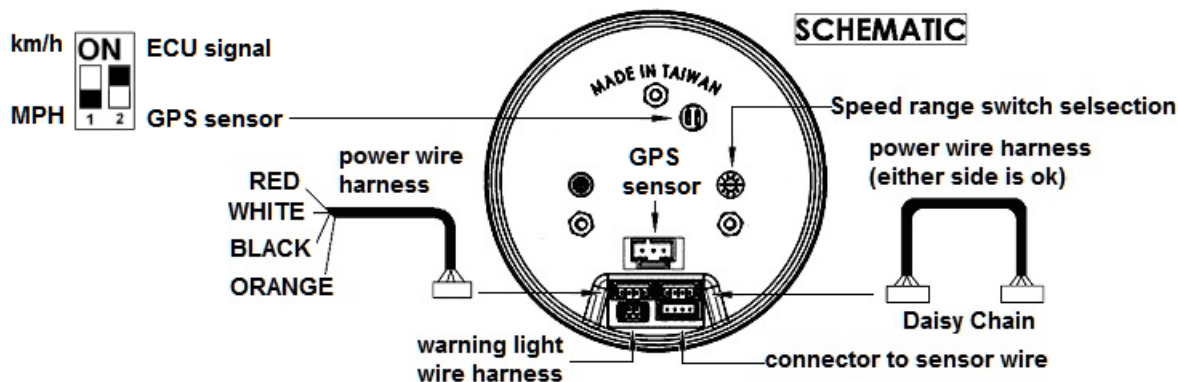

# INSTALLATION INSTRUCTIONS

## 85mm EVO SPEEDOMETER W/WARNING & PEAK

### WHITE/AMBER RED/BLUE/GREEN LED DISPLAY

---

**5 IMPROTANT:** Speedometer signal wire connect to the corresponding speed signal in the ECU signal diagram.

Always consult the service manual for the vehicle you working on to ensure proper connection.

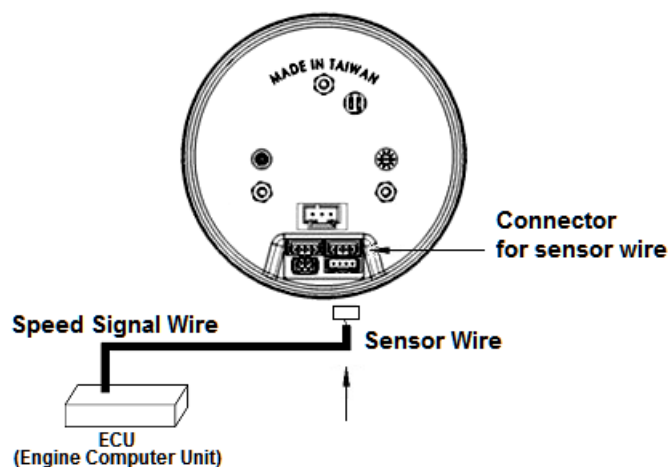

## 6 SPEEDOMETER ASSEMBLY

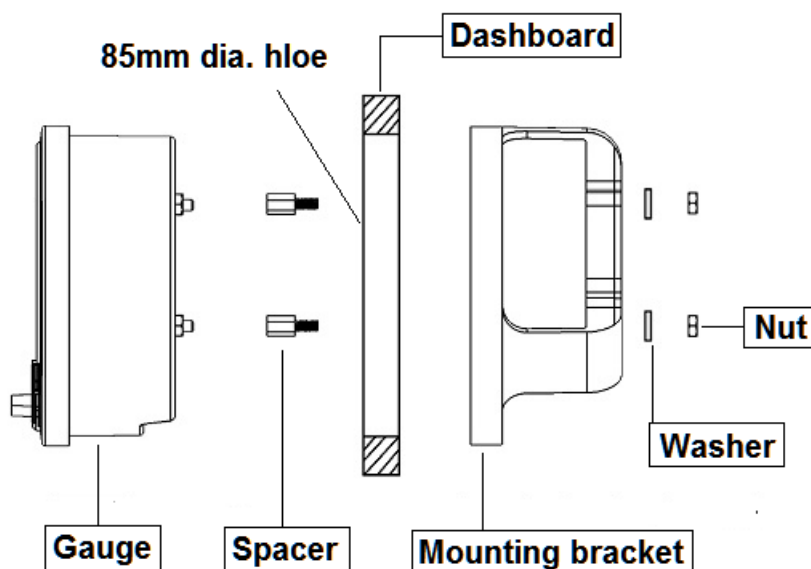

## 7 SPEED CALIBRATION

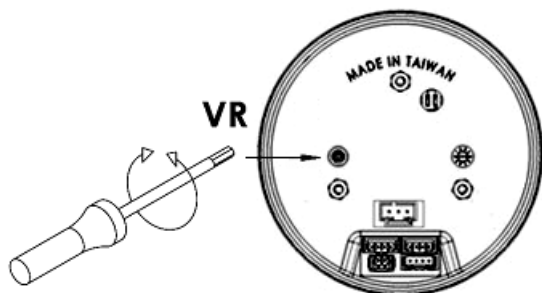

Use the VR roll, which is enclosed in our accessory pack, to adjust to the accurate SPEED.

It is recommended to connect with a SPEED standard gauge in order to adjust the SPEED.

# 85mm EVO SERIES SPEEDMETER OPERATION INSTRUCTIONS

There are six setting modes in this gauge, **Backlight color Mode**, **Peak Mode**, **Warning Mode**, **Backlight Brightness Mode**, **Sound Mode** and **Odometer Mode**. In any time when the gauge is in the normal mode, the Backlight color Mode can be operated by pressing < ▲ >. Press < M > to enter into the Peak Mode.

## 1. Backlight color Mode:

- 1) There are four different color LED backlight display in one gauge: White, Red, Green and Blue.
- 2) Press < ▲ > to select a backlight color in sequence.

## 2. Peak Mode:

- 1) Press < M > to enter into the Peak Mode.
- 2) After 5-second of no button activity or press < M >, the gauge will return to the normal mode.
- 3) When the peak value is displayed, press and hold < M > 3-second to clear the previous peak value.

## 3. Warning Mode:

- 1) Hold < M > for 3-second to enter to the warning mode.
- 2) When the WR LED is flashing, press < ▲ > or < ▼ > to adjust the warning value.
- 3) Press < M > or after 5-second of no button activity, the gauge will return to the normal mode.

## 4. Backlight Brightness Mode

There are six-stage for each daytime and nighttime backlight brightness available for users to select the preferred brightness.

- 1) Hold < ▲ > for 3-second to enter to the backlight brightness mode. When the PK and WR LED are flashing, the daytime brightness can be selected.
- 2) Press either < ▲ > or < ▼ > to select the backlight brightness.
- 3) In order to set the nighttime backlight brightness, the orange wire of the power wire harness should be connected to Dimmer/ 12V switched source (+).
- 4) When Dimmer/ 12V switched source (+) is on, the nighttime brightness can be selected.
- 5) Press < M > or after 5-second of no button activity, the gauge will return to the normal mode.

## 5. Sound Mode:

- 1) Hold < ▼ > for 3-second to switch the sound.
- 2) When the sound is enabled, you will hear two beep, vice versa, when it is disabled, you will hear one beep sound.

## 6. Odometer Mode:

There are three different readouts which are displayed on the LCD: ODOMETER, TRIP A and TRIP B .

### Odometer Mode:

- 1) Press < ▼ > to enter **odometer mode**. You can see “ODO” showing on the LCD screen.
- 2) When the gauge is in ODO mode, the odometer can not be reset.

### Trip A odometer Mode:

- 1) After programming **odometer mode**, press < ▼ > to enter **Trip A odometer mode** which “Trip A” is shown on the LCD screen.
- 2) When the gauge is in Trip A odometer mode, hold < ▲ > and < ▼ > for 3 seconds to reset the Trip B odometer.

### Trip B odometer Mode:

- 1) After programming **Trip A odometer mode**, press < ▼ > to enter **Trip B odometer mode** which “Trip B” is shown on the LCD screen.
- 2) When the gauge is in Trip B odometer mode, hold < ▲ > or < ▼ > for 3 seconds to reset the Trip B odometer.