

EVO SERIES WIDEBAND AIR/FUEL RATIO GAUGE

WITH 0-5V ANALOG OUTPUT

UEGO CONTROLLER INSTALLATION INSTRUCTIONS:

RED - 12V ACCESSORY POWER (+)

WHITE - 12V ACCESSORY POWER (+)

BLACK - ENGINE GROUND(-)

ORANGE - CONNECT TO HEADLIGHT SWITCH 12V(+). THIS WILL CHANGE THE GAUGE TO RED WHEN THE HEADLIGHTS ARE TURNED ON. IF YOU WANT THE GAUGE BLUE ALL THE TIME DO NOT CONNECT THE ORANGE WIRE TO ANYTHING JUST CAP IT OFF. TO RUN THE GAUGE RED ONLY SEE #5 BELOW FOR INSTRUCTIONS.

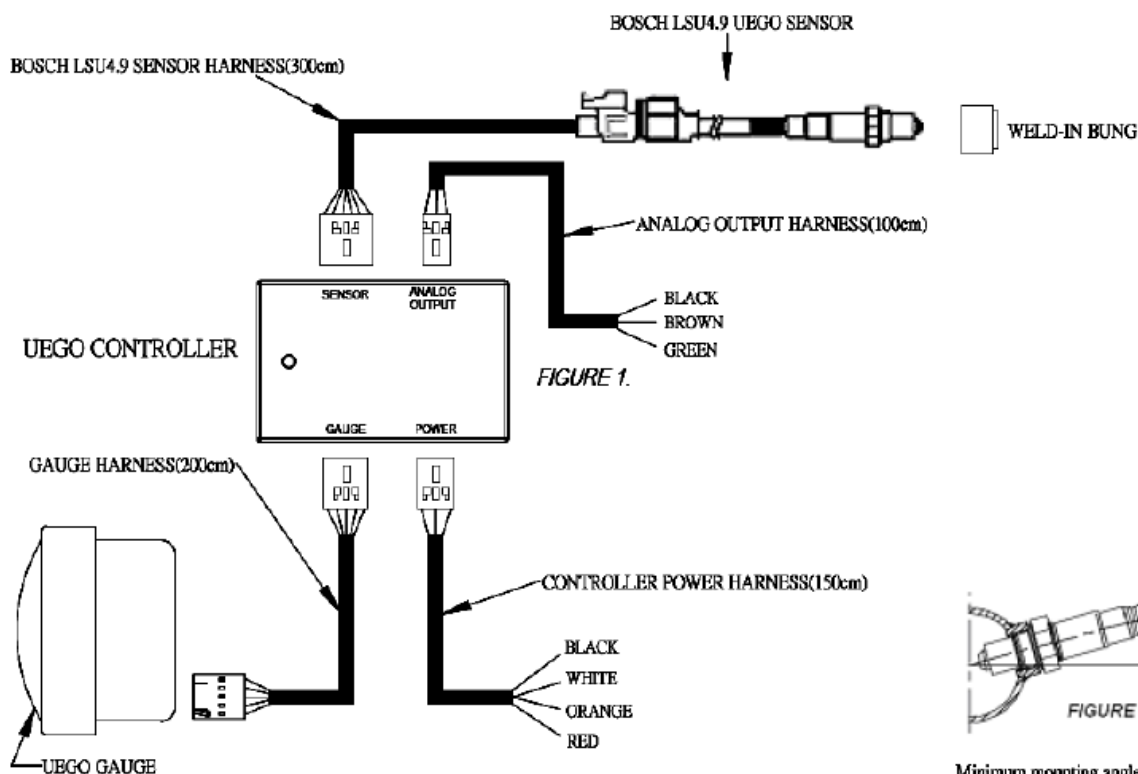

A WELD-IN M18 X 1.5 BOSS IS SUPPLIED FOR SENSOR INSTALLATION. MOUNT THE O2 SENSOR IN THE EXHAUST SYSTEM AT LEAST 18 INCHES DOWNSTREAM FROM THE EXHAUST PORT. IF YOU ANTICIPATE HIGH EGT'S (OVER 800C), RUN A TURBOCHARGER, RUN AT HIGH RPM FOR EXTENDED PERIODS OF TIME OR PLAN ON RUNNING LEADED RACE FUEL THEN YOU MUST MOUNT THE SENSOR AT LEAST 36 INCHES OR MORE DOWNSTREAM OF THE EXHAUST PORT AS ALL OF THESE CAN CAUSE THE SENSOR TO OVERHEAT. ON TURBOCHARGED ENGINES THE UEGO SENSOR MUST BE INSTALLED AFTER THE TURBO CHARGER, IF NOT, THE PRESSURE DIFFERENTIAL WILL GREATLY AFFECT THE ACCURACY OF THE UNIT. FOR ACCURATE READINGS, THE SENSOR MUST BE MOUNTED BEFORE CATALYTIC CONVERTERS AND/OR AUXILIARY AIR PUMPS. TO PREVENT COLLECTION OF LIQUIDS BETWEEN THE SENSOR HOUSING AND SENSOR ELEMENT DURING THE

COLD START PHASE, THE INSTALLATION ANGLE SHOULD BE INCLINED AT LEAST 10° FROM HORIZONTAL WITH THE ELECTRICAL CONNECTION UPWARDS, SEE ABOVE (FIGURE 2)

VOLT	LAMBDA	GASOLINE AFR
0.00	0.683	10.00
0.16	0.705	10.32
0.31	0.725	10.62
0.47	0.747	10.94
0.62	0.768	11.24
0.78	0.790	11.56
0.94	0.811	11.8
1.09	0.832	12.18
1.25	0.854	12.50
1.40	0.874	12.80
1.56	0.896	13.12
1.72	0.918	13.44
1.87	0.939	13.74
2.03	0.960	14.06
2.18	0.981	14.36
2.34	1.003	14.68
2.50	1.025	15.00
2.65	1.045	15.30
2.81	1.067	15.62
2.96	1.087	15.92
3.12	1.109	16.24
3.28	1.130	16.54
3.43	1.152	16.86
3.59	1.173	17.18
3.74	1.194	17.48
3.90	1.216	17.80
4.06	1.236	18.10
4.21	1.258	18.42
4.37	1.280	18.74
4.52	1.301	19.04
4.68	1.322	19.36
4.84	1.343	19.66
4.99	1.356	19.98

1. CALIBRATION MODE:

PRESS THE BUTTON ON THE CONTROLLER FOR 3 SECONDS TO CALIBRATE THE CONTROLLER. WHEN THE LED SCREEN DISPLAYS [2], THE CONTROLLER IS CALIBRATING.

2. SENSOR ERROR DIAGNOSIS:

WHEN THE LED SCREEN DISPLAYS [3], IT IS A SENSOR ERROR CODE. PLEASE CHECK IF THE SENSOR IS DISCONNECTED OR DEFECTIVE.

3. ORIGINAL MANUFACTURE SETTING MODE:

PRESS THE BUTTON THE CONTROLLER FOR 8 SECONDS TO OPERATE THE ORIGINAL MANUFACTURE SETTING OF THE CONTROLLER. THE LED SCREEN WILL DISPLAY [2] FIRST. AFTER THE LED SCREEN DISPLAYS [4], THE ORIGINAL MANUFACTURE SETTING IS PROGRAMMED.

4. ANALOG OUTPUT WIRE HARNESS INSTRUCTION:

BLACK – ENGINE GROUND

BROWN – WIDE BAND ANALOG OUTPUT 0-5V (0V → 10AFR, 5V → 20AFR)

GREEN – NARROW BAND ANALOG OUTPUT 0-1V (0V → 20AFR, 1V → 10AFR)

5. LIGHTING:

IF YOU WANT TO RUN THE GAUGE RED ALL THE TIME CONNECT THE RED AND WHITE WIRES TO 12V ACC. POWER AND BLACK TO GROUND. THEN USING A SMALL PICK TO PUSH THE SILVER PIN DOWN ON ONLY ONE SIDE OF THE GAUGE WIRE HARNESS CHANGE THE #2 (BROWN WIRE) WITH THE #4 (ORANGE WIRE).